

SSANGYONG MUSSO 2019>

KOD / CODE : 6714DKY111

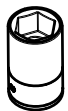

SW13 (20Nm)



SW17 (40Nm)

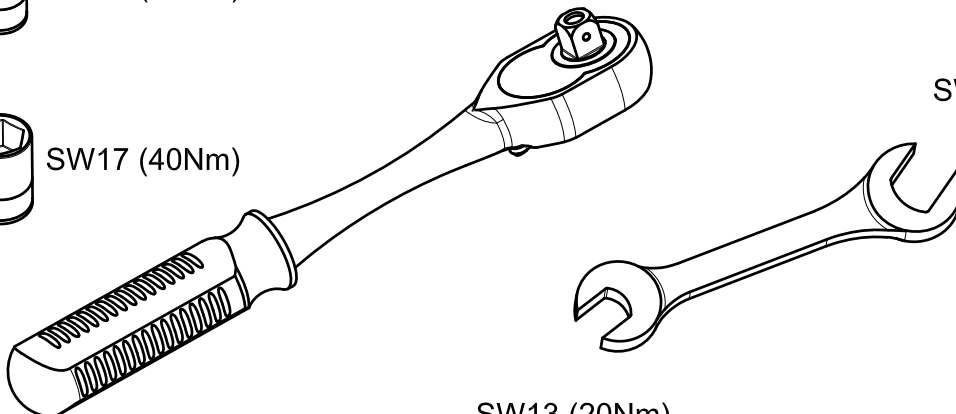

SW17 (40Nm)

SW13 (20Nm)

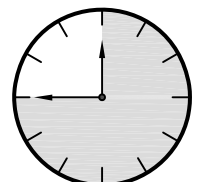

45 Min.

MONTAJ SETİ / INSTALLATION SET

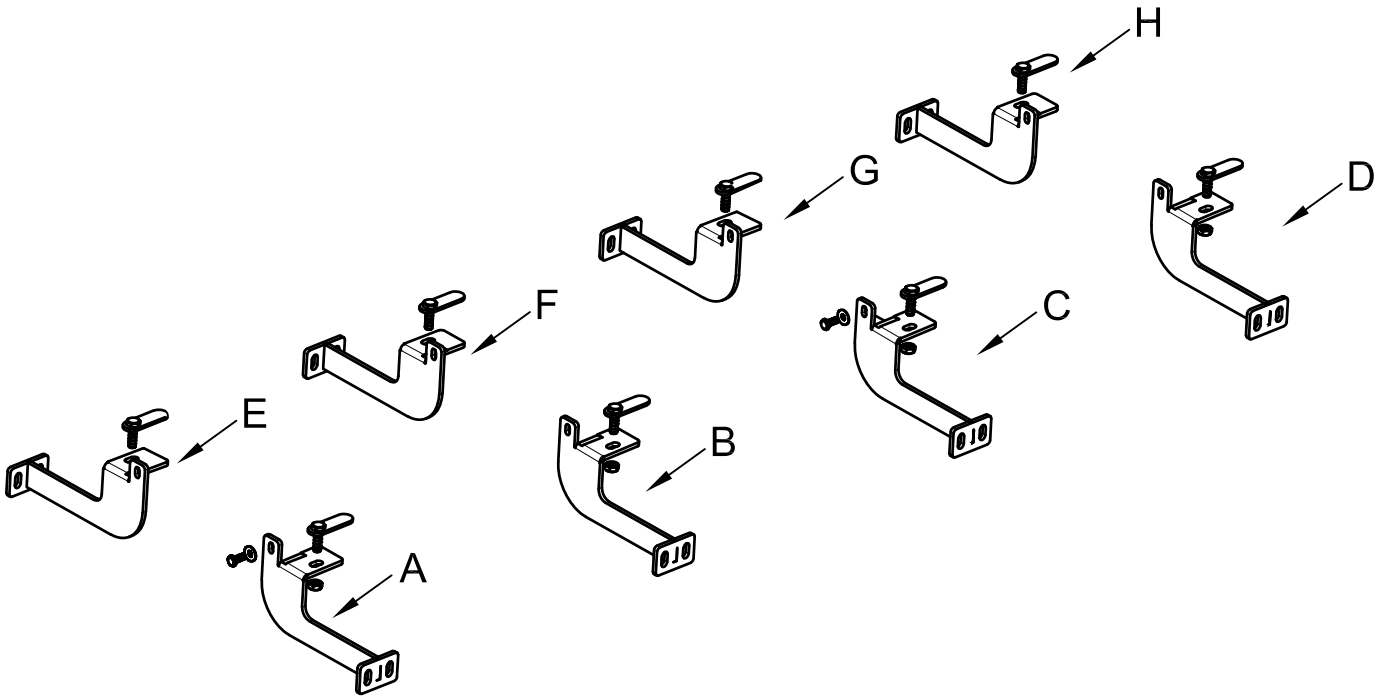
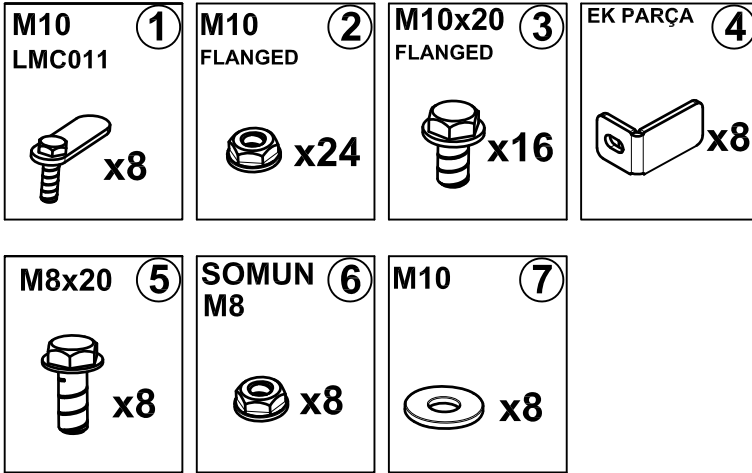

BRAKETLER / BRACKETS

- A. 6714 DKY L / SOL BRAKET / LEFT BRACKET
- B. 6714 DKY L / SOL BRAKET / LEFT BRACKET
- C. 6714 DKY L / SOL BRAKET / LEFT BRACKET
- D. 6714 DKY L / SOL BRAKET / LEFT BRACKET
- E. 6714 DKY R / SAĞ BRAKET / RIGHT BRACKET
- F. 6714 DKY R / SAĞ BRAKET / RIGHT BRACKET
- G. 6714 DKY R / SAĞ BRAKET / RIGHT BRACKET
- H. 6714 DKY R / SAĞ BRAKET / RIGHT BRACKET

Fig. 1



ARAÇ ÜZERİNDEKİ PLASTİK KAPAĞI SÖKÜNÜZ

PLEASE REMOVE THE STOPPER THAT ALREADY ATTACHED ON THE VEHICLE



LF

Fig. 5



ARAÇ ÜZERİNDEKİ PLASTİK KAPAĞI SÖKÜNÜZ

PLEASE REMOVE THE STOPPER THAT ALREADY ATTACHED ON THE VEHICLE



LM1

Fig. 2



ARAÇ ÜZERİNDEKİ PLASTİK KAPAĞI SÖKÜNÜZ

PLEASE REMOVE THE STOPPER THAT ALREADY ATTACHED ON THE VEHICLE



LF



Fig. 6



ARAÇ ÜZERİNDEKİ PLASTİK KAPAĞI SÖKÜNÜZ

PLEASE REMOVE THE STOPPER THAT ALREADY ATTACHED ON THE VEHICLE



LM1



Fig. 3



1 NUMARALI PARÇAYI YERİNE TAKINIZ

PLEASE ATTACH THE PART (PART NO 1) TO THE PLACE SHOWN ABOVE



LF

Fig. 7



1 NUMARALI PARÇAYI YERİNE TAKINIZ

PLEASE ATTACH THE PART (PART NO 1) TO THE PLACE SHOWN ABOVE



LM1

Fig. 4



BRAKETİ YERİNE TAKINIZ

INSTALL THE BRACKET WITH BOLTS



LF

Fig. 8



BRAKETİ YERİNE TAKINIZ

INSTALL THE BRACKET WITH BOLTS



LM1

Fig. 9



ARAÇ ÜZERİNDEKİ PLASTİK KAPAĞI SÖKÜNÜZ

PLEASE REMOVE THE STOPPER THAT
ALREADY ATTACHED ON THE VEHICLE



LR

Fig. 11



BRACKETLERİN ARAÇ ÜZERİNDEKİ YERLERİDİR

THE PLACES ARE ON THE VEHICLE

Fig. 10



ARAÇ ÜZERİNDEKİ PLASTİK KAPAĞI SÖKÜNÜZ

PLEASE REMOVE THE STOPPER THAT ALREADY
ATTACHED ON THE VEHICLE



LR



Fig. 12

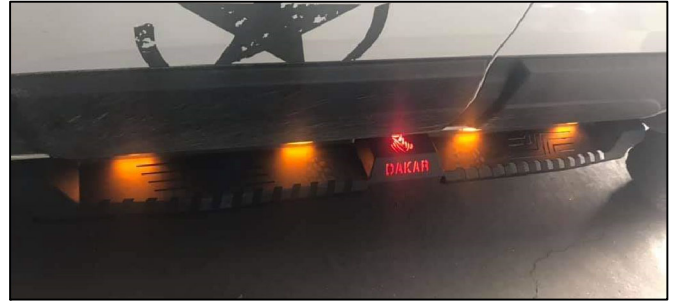

ÜRÜNÜ MONTAJLAYINIZ

PLEASE INSTALL THE PRODUCT

MONTAJ ŞEMASI / INSTALLATION SCHEME

